

**2023-2027 General Class  
FCC Element 3 Question Pool  
Effective 7/01/2023 – 6/30/2027**

G1A01 (C) [97.301(d)]

On which HF and/or MF amateur bands are there portions where General class licensees cannot transmit?

**C. 80 meters, 40 meters, 20 meters, and 15 meters**

G1A02 (B) [97.305]

On which of the following bands is phone operation prohibited?

**B. 30 meters**

G1A03 (B) [97.305]

On which of the following bands is image transmission prohibited?

**B. 30 meters**

G1A04 (D) [97.303(h)]

Which of the following amateur bands is restricted to communication only on specific channels, rather than frequency ranges?

**D. 60 meters**

G1A05 (A) [97.301(d)]

On which of the following frequencies are General class licensees prohibited from operating as control operator?

**A. 7.125 MHz to 7.175 MHz**

G1A06 (C) [97.303]

Which of the following applies when the FCC rules designate the amateur service as a secondary user on a band?

**C. Amateur stations must not cause harmful interference to primary users and must accept interference from primary users**

G1A07 (D) [97.305(a)]

On which amateur frequencies in the 10-meter band may stations with a General class control operator transmit CW emissions?

**D. The entire band**

G1A08 (B) [97.301(b)]

Which HF bands have segments exclusively allocated to Amateur Extra licensees?

**B. 80 meters, 40 meters, 20 meters, and 15 meters**

G1A09 (C) [97.301(d)]

Which of the following frequencies is within the General class portion of the 15-meter band?

**C. 21300 kHz**

G1A10 (D) [97.205(b)]

What portion of the 10-meter band is available for repeater use?

**D. The portion above 29.5 MHz**

G1A11 (B) [97.301]

When General class licensees are not permitted to use the entire voice portion of a band, which portion of the voice segment is available to them?

**B. The upper frequency portion**

G1B01 (C) [97.15(a)]

What is the maximum height above ground for an antenna structure not near a public use airport without requiring notification to the FAA and registration with the FCC?

**C. 200 feet**

G1B02 (A) [97.203(b)]

With which of the following conditions must beacon stations comply?

**A. No more than one beacon station may transmit in the same band from the same station location**

G1B03 (A) [97.3(a)(9)]

Which of the following is a purpose of a beacon station as identified in the FCC rules?

**A. Observation of propagation and reception**

G1B04 (C) [97.113(c)]

Which of the following transmissions is permitted for all amateur stations?

**C. Occasional retransmission of weather and propagation forecast information from US government stations**

G1B05 (B) [97.111((5)(b)]

Which of the following one-way transmissions are permitted?

**B. Transmissions to assist with learning the International Morse code**

G1B06 (D) [97.15(b), PRB-1, 101 FCC 2d 952 (1985)]

Under what conditions are state and local governments permitted to regulate amateur radio antenna structures?

**D. Amateur Service communications must be reasonably accommodated, and regulations must constitute the minimum practical to accommodate a legitimate purpose of the state or local entity**

G1B07 (B) [97.113(a)(4)]

What are the restrictions on the use of abbreviations or procedural signals in the amateur service?

**B. They may be used if they do not obscure the meaning of a message**

G1B08 (B) [97.111(a)(1)]

When is it permissible to communicate with amateur stations in countries outside the areas administered by the Federal Communications Commission?

**B. When the contact is with amateurs in any country except those whose administrations have notified the ITU that they object to such communications**

G1B09 (D) [97.203(d)]

On what HF frequencies are automatically controlled beacons permitted?

**D. 28.20 MHz to 28.30 MHz**

G1B10 (C) [97.203(c)]

What is the power limit for beacon stations?

C. 100 watts PEP output

G1B11 (A) [97.101(a)]

Who or what determines “good engineering and good amateur practice,” as applied to the operation of an amateur station in all respects not covered by the Part 97 rules?

A. The FCC

G1C01 (A) [97.313(c)(1)]

What is the maximum transmitter power an amateur station may use on 10.140 MHz?

A. 200 watts PEP output

G1C02 (C) [97.313]

What is the maximum transmitter power an amateur station may use on the 12-meter band?

C. 1500 watts PEP output

G1C03 (A) [97.303(h)(1)]

What is the maximum bandwidth permitted by FCC rules for amateur radio stations transmitting on USB frequencies in the 60-meter band?

A. 2.8 kHz

G1C04 (A) [97.303(i)]

Which of the following is required by the FCC rules when operating in the 60-meter band?

A. If you are using an antenna other than a dipole, you must keep a record of the gain of your antenna

G1C05 (C) [97.313]

What is the limit for transmitter power on the 28 MHz band for a General Class control operator?

C. 1500 watts PEP output

G1C06 (D) [97.313]

What is the limit for transmitter power on the 1.8 MHz band?

D. 1500 watts PEP output

G1C07 (C) [97.309(a)(4)]

What must be done before using a new digital protocol on the air?

C. Publicly document the technical characteristics of the protocol

G1C08 (D) [97.307(f)(3)]

What is the maximum symbol rate permitted for RTTY or data emission transmitted at frequencies below 28 MHz?

D. 300 baud

G1C09 (C) [97.313(i)]

What is the maximum power limit on the 60-meter band?

C. ERP of 100 watts PEP with respect to a dipole

G1C10 (C) [97.305(c) and 97.307(f)(4)]

What is the maximum symbol rate permitted for RTTY or data emission transmissions on the 10-meter band?

**C. 1200 baud**

G1C11 (D) [97.313]

What measurement is specified by FCC rules that regulate maximum power?

**D. PEP output from the transmitter**

G1D01 (A) [97.501, 97.505(a)]

Who may receive partial credit for the elements represented by an expired amateur radio license?

**A. Any person who can demonstrate that they once held an FCC-issued General, Advanced, or Amateur Extra class license that was not revoked by the FCC**

G1D02 (C) [97.509(b)(3)(i)]

What license examinations may you administer as an accredited Volunteer Examiner holding a General class operator license?

**C. Technician only**

G1D03 (C) [97.9(b)]

On which of the following band segments may you operate if you are a Technician class operator and have an unexpired Certificate of Successful Completion of Examination (CSCE) for General class privileges?

**C. On any General or Technician class band segment**

G1D04 (A) [97.509(3)(i)(c)]

Who must observe the administration of a Technician class license examination?

**A. At least three Volunteer Examiners of General class or higher**

G1D05 (A) [97.7]

When operating a US station by remote control from outside the country, what license is required of the control operator?

**A. A US operator/primary station license**

G1D06 (A) [97.119(f)(2)]

Until an upgrade to General class is shown in the FCC database, when must a Technician licensee identify with "AG" after their call sign?

**A. Whenever they operate using General class frequency privileges**

G1D07 (C) [97.509(b)(1)]

Volunteer Examiners are accredited by what organization?

**C. A Volunteer Examiner Coordinator**

G1D08 (B) [97.509(b)(3)]

Which of the following criteria must be met for a non-US citizen to be an accredited Volunteer Examiner?

**B. The person must hold an FCC granted amateur radio license of General class or above**

G1D09 (C) [97.9(b)]

How long is a Certificate of Successful Completion of Examination (CSCE) valid for exam element credit?

**C. 365 days**

G1D10 (B) [97.509(b)(2)]

What is the minimum age that one must be to qualify as an accredited Volunteer Examiner?

**B. 18 years**

G1D11 (D) [97.505]

What action is required to obtain a new General class license after a previously held license has expired and the two-year grace period has passed?

**D. The applicant must show proof of the appropriate expired license grant and pass the current Element 2 exam**

G1D12 (C) [97.507]

When operating a station in South America by remote control over the internet from the US, what regulations apply?

**C. Only those of the remote station's country**

G1E01 (A) [97.115(b)(2)]

Which of the following would disqualify a third party from participating in sending a message via an amateur station?

**A. The third party's amateur license has been revoked and not reinstated**

G1E02 (D) [97.205(b)]

When may a 10-meter repeater retransmit the 2-meter signal from a station that has a Technician class control operator?

**D. Only if the 10-meter repeater control operator holds at least a General class license**

G1E03 (A) [97.221]

What is required to conduct communications with a digital station operating under automatic control outside the automatic control band segments?

**A. The station initiating the contact must be under local or remote control**

G1E04 (D) [97.13(b), 97.303, 97.311(b)]

Which of the following conditions require a licensed amateur radio operator to take specific steps to avoid harmful interference to other users or facilities?

**D. All these choices are correct**

G1E05 (C) [97.115(a)(2), 97.117]

What are the restrictions on messages sent to a third party in a country with which there is a Third-Party Agreement?

**C. They must relate to amateur radio, or remarks of a personal character, or messages relating to emergencies or disaster relief**

G1E06 (C) [97.301, ITU Radio Regulations]

The frequency allocations of which ITU region apply to radio amateurs operating in North and South America?

**C. Region 2**

G1E07 (D) [97.111]

In what part of the 2.4 GHz band may an amateur station communicate with non-licensed Wi-Fi stations?

**D. No part**

G1E08 (B) [97.313(j)]

What is the maximum PEP output allowed for spread spectrum transmissions?

**B. 10 watts**

G1E09 (A) [97.115]

Under what circumstances are messages that are sent via digital modes exempt from Part 97 third-party rules that apply to other modes of communication?

**A. Under no circumstances**

G1E10 (A) [97.101]

Why should an amateur operator normally avoid transmitting on 14.100, 18.110, 21.150, 24.930 and 28.200 MHz?

**A. A system of propagation beacon stations operates on those frequencies**

G1E11 (D) [97.221, 97.305]

On what bands may automatically controlled stations transmitting RTTY or data emissions communicate with other automatically controlled digital stations?

**D. Anywhere in the 6-meter or shorter wavelength bands, and in limited segments of some of the HF bands**

G1E12 (A) [97.115]

When may third-party messages be transmitted via remote control?

**A. Under any circumstances in which third party messages are permitted by FCC rules**

G2A01 (A)

Which mode is most commonly used for voice communications on frequencies of 14 MHz or higher?

**A. Upper sideband**

G2A02 (B)

Which mode is most commonly used for voice communications on the 160-, 75-, and 40-meter bands?

**B. Lower sideband**

G2A03 (A)

Which mode is most commonly used for SSB voice communications in the VHF and UHF bands?

**A. Upper sideband**

G2A04 (A)

Which mode is most commonly used for voice communications on the 17- and 12-meter bands?

**A. Upper sideband**

G2A05 (C)

Which mode of voice communication is most commonly used on the HF amateur bands?

**C. Single sideband**

G2A06 (D)

Which of the following is an advantage of using single sideband, as compared to other analog voice modes on the HF amateur bands?

**D. Less bandwidth used and greater power efficiency**

G2A07 (B)

Which of the following statements is true of single sideband (SSB)?

**B. Only one sideband is transmitted; the other sideband and carrier are suppressed**

G2A08 (B)

What is the recommended way to break into a phone contact?

**B. Say your call sign once**

G2A09 (D)

Why do most amateur stations use lower sideband on the 160-, 75-, and 40-meter bands?

**D. It is commonly accepted amateur practice**

G2A10 (B)

Which of the following statements is true of VOX operation versus PTT operation?

**B. It allows "hands free" operation**

G2A11 (C)

Generally, who should respond to a station in the contiguous 48 states calling "CQ DX"?

**C. Any stations outside the lower 48 states**

G2A12 (B)

What control is typically adjusted for proper ALC setting on a single sideband transceiver?

**B. Transmit audio or microphone gain**

G2B01 (C) [97.101(b), (c)]

Which of the following is true concerning access to frequencies?

**C. Except during emergencies, no amateur station has priority access to any frequency**

G2B02 (B)

What is the first thing you should do if you are communicating with another amateur station and hear a station in distress break in?

**B. Acknowledge the station in distress and determine what assistance may be needed**

G2B03 (C)

What is good amateur practice if propagation changes during a contact creating interference from other stations using the frequency?

**C. Attempt to resolve the interference problem with the other stations in a mutually acceptable manner**

G2B04 (B)

When selecting a CW transmitting frequency, what minimum separation from other stations should be used to minimize interference to stations on adjacent frequencies?

**B. 150 Hz to 500 Hz**

G2B05 (C)

When selecting an SSB transmitting frequency, what minimum separation should be used to minimize interference to stations on adjacent frequencies?

**C. 2 kHz to 3 kHz**

G2B06 (A)

How can you avoid harmful interference on an apparently clear frequency before calling CQ on CW or phone?

A. Send "QRL?" on CW, followed by your call sign; or, if using phone, ask if the frequency is in use, followed by your call sign

G2B07 (C)

Which of the following complies with commonly accepted amateur practice when choosing a frequency on which to initiate a call?

C. Follow the voluntary band plan

G2B08 (A)

What is the voluntary band plan restriction for US stations transmitting within the 48 contiguous states in the 50.1 MHz to 50.125 MHz band segment?

A. Only contacts with stations not within the 48 contiguous states

G2B09 (A) [97.407(a)]

Who may be the control operator of an amateur station transmitting in RACES to assist relief operations during a disaster?

A. Only a person holding an FCC-issued amateur operator license

G2B10 (B)

Which of the following is good amateur practice for net management?

B. Have a backup frequency in case of interference or poor conditions

G2B11 (C) [97.407(d)(4)]

How often may RACES training drills and tests be routinely conducted without special authorization?

C. No more than 1 hour per week

G2C01 (D)

Which of the following describes full break-in CW operation (QSK)?

D. Transmitting stations can receive between code characters and elements

G2C02 (A)

What should you do if a CW station sends "QRS?"

A. Send slower

G2C03 (C)

What does it mean when a CW operator sends "KN" at the end of a transmission?

C. Listening only for a specific station or stations

G2C04 (D)

What does the Q signal "QRL?" mean?

D. "Are you busy?" or "Is this frequency in use?"

G2C05 (B)

What is the best speed to use when answering a CQ in Morse code?

B. The fastest speed at which you are comfortable copying, but no faster than the CQ



G2C06 (D)

What does the term “zero beat” mean in CW operation?

D. Matching the transmit frequency to the frequency of a received signal

G2C07 (A)

When sending CW, what does a “C” mean when added to the RST report?

A. Chirpy or unstable signal

G2C08 (C)

What prosign is sent to indicate the end of a formal message when using CW?

C. AR

G2C09 (C)

What does the Q signal “QSL” mean?

C. I have received and understood

G2C10 (D)

What does the Q signal “QRN” mean?

D. I am troubled by static

G2C11 (D)

What does the Q signal “QRV” mean?

D. I am ready to receive

G2D01 (A)

What is the Volunteer Monitor Program?

A. Amateur volunteers who are formally enlisted to monitor the airwaves for rules violations

G2D02 (D)

Which of the following are objectives of the Volunteer Monitor Program?

D. To encourage amateur radio operators to self-regulate and comply with the rules

G2D03 (B)

What procedure may be used by Volunteer Monitors to localize a station whose continuous carrier is holding a repeater on in their area?

B. Compare beam headings on the repeater input from their home locations with that of other Volunteer Monitors

G2D04 (B)

Which of the following describes an azimuthal projection map?

B. A map that shows true bearings and distances from a specific location

G2D05 (C)

Which of the following indicates that you are looking for an HF contact with any station?

C. Repeat “CQ” a few times, followed by “this is,” then your call sign a few times, then pause to listen, repeat as necessary

G2D06 (C)

How is a directional antenna pointed when making a “long-path” contact with another station?

C. 180 degrees from the station’s short-path heading

G2D07 (D)

Which of the following are examples of the NATO Phonetic Alphabet?

D. Alpha, Bravo, Charlie, Delta

G2D08 (D)

Why do many amateurs keep a station log?

D. To help with a reply if the FCC requests information about your station

G2D09 (C)

Which of the following is required when participating in a contest on HF frequencies?

C. Identify your station according to normal FCC regulations

G2D10 (B)

What is QRP operation?

B. Low-power transmit operation

G2D11 (A)

Why are signal reports typically exchanged at the beginning of an HF contact?

A. To allow each station to operate according to conditions

G2E01 (D)

Which mode is normally used when sending RTTY signals via AFSK with an SSB transmitter?

D. LSB

G2E02 (B)

What is VARA?

B. A digital protocol used with Winlink

G2E03 (D)

What symptoms may result from other signals interfering with a PACTOR or VARA transmission?

- A. Frequent retries or timeouts
- B. Long pauses in message transmission
- C. Failure to establish a connection between stations
- D. All these choices are correct

G2E04 (D)

Which of the following is good practice when choosing a transmitting frequency to answer a station calling CQ using FT8?

D. Find a clear frequency during the alternate time slot to the calling station

G2E05 (B)

What is the standard sideband for JT65, JT9, FT4, or FT8 digital signal when using AFSK?

B. USB

G2E06 (B)

What is the most common frequency shift for RTTY emissions in the amateur HF bands?

**B. 170 Hz**

G2E07 (B)

Which of the following is required when using FT8?

**B. Computer time accurate to within approximately 1 second**

G2E08 (D)

In what segment of the 20-meter band are most digital mode operations commonly found?

**D. Between 14.070 MHz and 14.100 MHz**

G2E09 (C)

How do you join a contact between two stations using the PACTOR protocol?

**C. Joining an existing contact is not possible, PACTOR connections are limited to two stations**

G2E10 (D)

Which of the following is a way to establish contact with a digital messaging system gateway station?

**D. Transmit a connect message on the station's published frequency**

G2E11 (C)

What is the primary purpose of an Amateur Radio Emergency Data Network (AREDN) mesh network?

**C. To provide high-speed data services during an emergency or community event**

G2E12 (D)

Which of the following describes Winlink?

**A. An amateur radio wireless network to send and receive email on the internet**

**B. A form of Packet Radio**

**C. A wireless network capable of both VHF and HF band operation**

**D. All of the above**

G2E13 (B)

What is another name for a Winlink Remote Message Server?

**B. Gateway**

G2E14 (D)

What could be wrong if you cannot decode an RTTY or other FSK signal even though it is apparently tuned in properly?

**D. All these choices are correct**

G2E15 (C)

Which of the following is a common location for FT8?

**C. Approximately 14.074 MHz to 14.077 MHz**

G3A01 (A)

How does a higher sunspot number affect HF propagation?

**A. Higher sunspot numbers generally indicate a greater probability of good propagation at higher frequencies**

G3A02 (B)

What effect does a sudden ionospheric disturbance have on the daytime ionospheric propagation?

**B. It disrupts signals on lower frequencies more than those on higher frequencies**

G3A03 (C)

Approximately how long does it take the increased ultraviolet and X-ray radiation from a solar flare to affect radio propagation on Earth?

**C. 8 minutes**

G3A04 (D)

Which of the following are the least reliable bands for long-distance communications during periods of low solar activity?

**D. 15 meters, 12 meters, and 10 meters**

G3A05 (D)

What is the solar flux index?

**D. A measure of solar radiation with a wavelength of 10.7 centimeters**

G3A06 (D)

What is a geomagnetic storm?

**D. A temporary disturbance in Earth's geomagnetic field**

G3A07 (D)

At what point in the solar cycle does the 20-meter band usually support worldwide propagation during daylight hours?

**D. At any point**

G3A08 (D)

How can a geomagnetic storm affect HF propagation?

**D. Degrade high-latitude HF propagation**

~~

G3A09 (A)

How can high geomagnetic activity benefit radio communications?

**A. Creates auroras that can reflect VHF signals**

G3A10 (C)

What causes HF propagation conditions to vary periodically in a 26- to 28-day cycle?

**C. Rotation of the Sun's surface layers around its axis**

G3A11 (D)

How long does it take a coronal mass ejection to affect radio propagation on Earth?

**D. 15 hours to several days**

G3A12 (B)

What does the K-index measure?

**B. The short-term stability of Earth's geomagnetic field**

G3A13 (C)

What does the A-index measure?

C. The long-term stability of Earth's geomagnetic field~

G3A14 (B)

How is long distance radio communication usually affected by the charged particles that reach Earth from solar coronal holes?

B. HF communication is disturbed

G3B01 (D)

What is a characteristic of skywave signals arriving at your location by both short-path and long-path propagation?

D. A slightly delayed echo might be heard

G3B02 (D)

What factors affect the MUF?

A. Path distance and location

B. Time of day and season

C. Solar radiation and ionospheric disturbances

D. All these choices are correct

G3B03 (A)

Which frequency will have the least attenuation for long-distance skip propagation?

A. Just below the MUF

G3B04 (A)

Which of the following is a way to determine current propagation on a desired band from your station?

A. Use a network of automated receiving stations on the internet to see where your transmissions are being received

G3B05 (A)

How does the ionosphere affect radio waves with frequencies below the MUF and above the LUF?

A. They are refracted back to Earth

G3B06 (C)

What usually happens to radio waves with frequencies below the LUF?

C. They are attenuated before reaching the destination

G3B07 (A)

What does LUF stand for?

A. The Lowest Usable Frequency for communications between two specific points

G3B08 (B)

What does MUF stand for?

B. The Maximum Usable Frequency for communications between two points

G3B09 (C)

What is the approximate maximum distance along the Earth's surface normally covered in one hop using the F2 region?

C. 2,500 miles

G3B10 (B)

What is the approximate maximum distance along the Earth's surface normally covered in one hop using the E region?

B. 1,200 miles

G3B11 (A)

What happens to HF propagation when the LUF exceeds the MUF?

A. Propagation via ordinary skywave communications is not possible over that path

G3B12 (D)

Which of the following is typical of the lower HF frequencies during the summer?

D. High levels of atmospheric noise or static

G3C01 (A)

Which ionospheric region is closest to the surface of Earth?

A. The D region

G3C02 (A)

What is meant by the term "critical frequency" at a given incidence angle?

A. The highest frequency which is refracted back to Earth

G3C03 (C)

Why is skip propagation via the F2 region longer than that via the other ionospheric regions?

C. Because it is the highest

G3C04 (D)

What does the term "critical angle" mean, as applied to radio wave propagation?

D. The highest takeoff angle that will return a radio wave to Earth under specific ionospheric conditions~

G3C05 (C)

Why is long-distance communication on the 40-, 60-, 80-, and 160-meter bands more difficult during the day?

C. The D region absorbs signals at these frequencies during daylight hours

G3C06 (B)

What is a characteristic of HF scatter?

B. Signals have a fluttering sound

G3C07 (D)

What makes HF scatter signals often sound distorted?

D. Energy is scattered into the skip zone through several different paths

G3C08 (A)

Why are HF scatter signals in the skip zone usually weak?

A. Only a small part of the signal energy is scattered into the skip zone

G3C09 (B)

What type of propagation allows signals to be heard in the transmitting station's skip zone?

B. Scatter

G3C10 (B)

What is near vertical incidence skywave (NVIS) propagation?

B. Short distance MF or HF propagation at high elevation angles

G3C11 (D)

Which ionospheric region is the most absorbent of signals below 10 MHz during daylight hours?

D. The D region

G4A01 (B)

What is the purpose of the notch filter found on many HF transceivers?

B. To reduce interference from carriers in the receiver passband

G4A02 (C)

What is the benefit of using the opposite or "reverse" sideband when receiving CW?

C. It may be possible to reduce or eliminate interference from other signals

G4A03 (C)

How does a noise blanker work?

C. By reducing receiver gain during a noise pulse

G4A04 (B)

What is the effect on plate current of the correct setting of a vacuum-tube RF power amplifier's TUNE control?

B. A pronounced dip

G4A05 (C)

Why is automatic level control (ALC) used with an RF power amplifier?

C. To prevent excessive drive

G4A06 (C)

What is the purpose of an antenna tuner?

C. Increase power transfer from the transmitter to the feed line

G4A07 (A)

What happens as a receiver's noise reduction control level is increased?

A. Received signals may become distorted

G4A08 (D)

What is the correct adjustment for the LOAD or COUPLING control of a vacuum tube RF power amplifier?

D. Desired power output without exceeding maximum allowable plate current

G4A09 (C)

What is the purpose of delaying RF output after activating a transmitter's keying line to an external amplifier?

C. To allow time for the amplifier to switch the antenna between the transceiver and the amplifier output

G4A10 (B)

What is the function of an electronic keyer?

B. Automatic generation of dots and dashes for CW operation

G4A11 (B)

Why should the ALC system be inactive when transmitting AFSK data signals?

B. The ALC action distorts the signal

G4A12 (C)

Which of the following is a common use of the dual-VFO feature on a transceiver?

C. To transmit on one frequency and listen on another

G4A13 (A)

What is the purpose of using a receive attenuator?

A. To prevent receiver overload from strong incoming signals

G4B01 (D)

What item of test equipment contains horizontal and vertical channel amplifiers?

D. An oscilloscope

G4B02 (D)

Which of the following is an advantage of an oscilloscope versus a digital voltmeter?

D. Complex waveforms can be measured

G4B03 (A)

Which of the following is the best instrument to use for checking the keying waveform of a CW transmitter?

A. An oscilloscope

G4B04 (D)

What signal source is connected to the vertical input of an oscilloscope when checking the RF envelope pattern of a transmitted signal?

D. The attenuated RF output of the transmitter

G4B05 (D)

Why do voltmeters have high input impedance?

D. It decreases the loading on circuits being measured

G4B06 (C)

What is an advantage of a digital multimeter as compared to an analog multimeter?

C. Higher precision

G4B07 (B)

What signals are used to conduct a two-tone test?

B. Two non-harmonically related audio signals



G4B08 (A)

What transmitter performance parameter does a two-tone test analyze?

A. Linearity

B. Percentage of suppression of the carrier and undesired sideband for SSB

G4B09 (D)

When is an analog multimeter preferred to a digital multimeter?

D. When adjusting circuits for maximum or minimum values

G4B10 (A)

Which of the following can be determined with a directional wattmeter?

A. Standing wave ratio

G4B11 (C)

Which of the following must be connected to an antenna analyzer when it is being used for SWR measurements?

C. Antenna and feed line

G4B12 (B)

What effect can strong signals from nearby transmitters have on an antenna analyzer?

B. Received power that interferes with SWR readings

G4B13 (C)

Which of the following can be measured with an antenna analyzer?

C. Impedance of coaxial cable

G4C01 (B)

Which of the following might be useful in reducing RF interference to audio frequency circuits?

B. Bypass capacitor

G4C02 (C)

Which of the following could be a cause of interference covering a wide range of frequencies?

C. Arcing at a poor electrical connection

G4C03 (C)

What sound is heard from an audio device experiencing RF interference from a single sideband phone transmitter?

C. Distorted speech

G4C04 (A)

What sound is heard from an audio device experiencing RF interference from a CW transmitter?

A. On-and-off humming or clicking

G4C05 (D)

What is a possible cause of high voltages that produce RF burns?

D. The ground wire has high impedance on that frequency

G4C06 (C)

What is a possible effect of a resonant ground connection?

C. High RF voltages on the enclosures of station equipment

G4C07 (A)

Why should soldered joints not be used in lightning protection ground connections?

A. A soldered joint will likely be destroyed by the heat of a lightning strike

G4C08 (A)

Which of the following would reduce RF interference caused by common-mode current on an audio cable?

A. Place a ferrite choke on the cable

G4C09 (D)

How can the effects of ground loops be minimized?

D. Bond equipment enclosures together

G4C10 (A)

What could be a symptom caused by a ground loop in your station's audio connections?

A. You receive reports of "hum" on your station's transmitted signal

G4C11 (C)

What technique helps to minimize RF "hot spots" in an amateur station?

C. Bonding all equipment enclosures together

G4C12 (D)

Why must all metal enclosures of station equipment be grounded?

D. It ensures that hazardous voltages cannot appear on the chassis

G4D01 (A)

What is the purpose of a speech processor in a transceiver?

A. Increase the apparent loudness of transmitted voice signals

G4D02 (B)

How does a speech processor affect a single sideband phone signal?

B. It increases average power

G4D03 (D)

What is the effect of an incorrectly adjusted speech processor?

A. Distorted speech

B. Excess intermodulation products

C. Excessive background noise

D. All these choices are correct

G4D04 (C)

What does an S meter measure?

C. Received signal strength

G4D05 (D)

How does a signal that reads 20 dB over S9 compare to one that reads S9 on a receiver, assuming a properly calibrated S meter?

**D. It is 100 times more powerful**

G4D06 (A)

How much change in signal strength is typically represented by one S unit?

**A. 6 dB**

G4D07 (C)

How much must the power output of a transmitter be raised to change the S meter reading on a distant receiver from S8 to S9?

**C. Approximately 4 times**

G4D08 (C)

What frequency range is occupied by a 3 kHz LSB signal when the displayed carrier frequency is set to 7.178 MHz?

**C. 7.175 MHz to 7.178 MHz**

G4D09 (B)

What frequency range is occupied by a 3 kHz USB signal with the displayed carrier frequency set to 14.347 MHz?

**B. 14.347 MHz to 14.350 MHz**

G4D10 (A)

How close to the lower edge of a band's phone segment should your displayed carrier frequency be when using 3 kHz wide LSB?

**A. At least 3 kHz above the edge of the segment**

G4D11 (B)

How close to the upper edge of a band's phone segment should your displayed carrier frequency be when using 3 kHz wide USB?

**B. At least 3 kHz below the edge of the band**

G4E01 (C)

What is the purpose of a capacitance hat on a mobile antenna?

**C. To electrically lengthen a physically short antenna**

G4E02 (D)

What is the purpose of a corona ball on an HF mobile antenna?

**D. To reduce RF voltage discharge from the tip of the antenna while transmitting**

G4E03 (A)

Which of the following direct, fused power connections would be the best for a 100-watt HF mobile installation?

**A. To the battery using heavy-gauge wire**

G4E04 (B)

Why should DC power for a 100-watt HF transceiver not be supplied by a vehicle's auxiliary power socket?

**B. The socket's wiring may be inadequate for the current drawn by the transceiver**

G4E05 (C)

Which of the following most limits an HF mobile installation?

C. Efficiency of the electrically short antenna

G4E06 (C)

What is one disadvantage of using a shortened mobile antenna as opposed to a full-size antenna?

C. Operating bandwidth may be very limited

G4E07 (D)

Which of the following may cause receive interference to an HF transceiver installed in a vehicle?

D. All these choices are correct

G4E08 (A)

In what configuration are the individual cells in a solar panel connected together?

A. Series-parallel

G4E09 (B)

What is the approximate open-circuit voltage from a fully illuminated silicon photovoltaic cell?

B. 0.5 VDC

G4E10 (B)

Why should a series diode be connected between a solar panel and a storage battery that is being charged by the panel?

B. To prevent discharge of the battery through the panel during times of low or no illumination

G4E11 (D)

What precaution should be taken when connecting a solar panel to a lithium iron phosphate battery?

D. The solar panel must have a charge controller

G5A01 (C)

What happens when inductive and capacitive reactance are equal in a series LC circuit?

C. Resonance causes impedance to be very low

G5A02 (B)

What is reactance?

B. Opposition to the flow of alternating current caused by capacitance or inductance

G5A03 (D)

Which of the following is opposition to the flow of alternating current in an inductor?

D. Reactance

G5A04 (C)

Which of the following is opposition to the flow of alternating current in a capacitor?

C. Reactance

G5A05 (D)

How does an inductor react to AC?

D. As the frequency of the applied AC increases, the reactance increases

G5A06 (A)

How does a capacitor react to AC?

A. As the frequency of the applied AC increases, the reactance decreases

G5A07 (D)

What is the term for the inverse of impedance?

D. Admittance

G5A08 (C)

What is impedance?

C. The ratio of voltage to current

G5A09 (B)

What unit is used to measure reactance?

B. Ohm

G5A10 (D)

Which of the following devices can be used for impedance matching at radio frequencies?

A. A transformer

B. A Pi-network

C. A length of transmission line

D. All these choices are correct

G5A11 (B)

What letter is used to represent reactance?

B. X

G5A12 (D)

What occurs in an LC circuit at resonance?

D. Inductive reactance and capacitive reactance cancel

G5B01 (B)

What dB change represents a factor of two increase or decrease in power?

B. Approximately 3 dB

G5B02 (C)

How does the total current relate to the individual currents in a circuit of parallel resistors?

C. It equals the sum of the currents through each branch

G5B03 (B)

How many watts of electrical power are consumed if 400 VDC is supplied to an 800-ohm load?

B. 200 watts

G5B04 (A)

How many watts of electrical power are consumed by a 12 VDC light bulb that draws 0.2 amperes?

A. 2.4 watts

G5B05 (A)

How many watts are consumed when a current of 7.0 milliamperes flows through a 1,250-ohm resistance?

A. Approximately 61 milliwatts

G5B06 (B)

What is the PEP produced by 200 volts peak-to-peak across a 50-ohm dummy load?

B. 100 watts

G5B07 (C)

What value of an AC signal produces the same power dissipation in a resistor as a DC voltage of the same value?

C. The RMS value

G5B08 (D)

What is the peak-to-peak voltage of a sine wave with an RMS voltage of 120 volts?

D. 339.4 volts

G5B09 (B)

What is the RMS voltage of a sine wave with a value of 17 volts peak?

B. 12 volts

G5B10 (C)

What percentage of power loss is equivalent to a loss of 1 dB?

C. 20.6 percent

G5B11 (B)

What is the ratio of PEP to average power for an unmodulated carrier?

B. 1.00

G5B12 (B)

What is the RMS voltage across a 50-ohm dummy load dissipating 1200 watts?

B. 245 volts

G5B13 (B)

What is the output PEP of an unmodulated carrier if the average power is 1060 watts?

B. 1060 watts

G5B14 (B)

What is the output PEP of 500 volts peak-to-peak across a 50-ohm load?

B. 625 watts

G5C01 (C)

What causes a voltage to appear across the secondary winding of a transformer when an AC voltage source is connected across its primary winding?

C. Mutual inductance

G5C02 (A)

What is the output voltage if an input signal is applied to the secondary winding of a 4:1 voltage step-down transformer instead of the primary winding?

A. The input voltage is multiplied by 4

G5C03 (A)

What is the total resistance of a 10-, a 20-, and a 50-ohm resistor connected in parallel?

A. 5.9 ohms

G5C04 (D)

What is the approximate total resistance of a 100- and a 200-ohm resistor in parallel?

D. 67 ohms

G5C05 (B)

Why is the primary winding wire of a voltage step-up transformer usually a larger size than that of the secondary winding?

B. To accommodate the higher current of the primary

G5C06 (A)

What is the voltage output of a transformer with a 500-turn primary and a 1500-turn secondary when 120 VAC is applied to the primary?

A. 360 volts

G5C07 (A)

What transformer turns ratio matches an antenna's 600-ohm feed point impedance to a 50-ohm coaxial cable?

A. 3.5 to 1

G5C08 (D)

What is the equivalent capacitance of two 5.0-nanofarad capacitors and one 750-picofarad capacitor connected in parallel?

D. 10.750 nanofarads

G5C09 (C)

What is the capacitance of three 100-microfarad capacitors connected in series?

C. 33.3 microfarads

G5C10 (C)

What is the inductance of three 10-millihenry inductors connected in parallel?

C. 3.3 millihenries

G5C11 (C)

What is the inductance of a circuit with a 20-millihenry inductor connected in series with a 50-millihenry inductor?

C. 70 millihenries

G5C12 (B)

What is the capacitance of a 20-microfarad capacitor connected in series with a 50-microfarad capacitor?

**B. 14.3 microfarads**

G5C13 (C)

Which of the following components should be added to a capacitor to increase the capacitance?

**C. A capacitor in parallel**

G5C14 (D)

Which of the following components should be added to an inductor to increase the inductance?

**D. An inductor in series**

G6A01 (C)

What is the minimum allowable discharge voltage for maximum life of a standard 12-volt lead-acid battery?

**C. 10.5 volts**

G6A02 (B)

What is an advantage of batteries with low internal resistance?

**B. High discharge current**

G6A03 (B)

What is the approximate forward threshold voltage of a germanium diode?

**B. 0.3 volts**

G6A04 (C)

Which of the following is characteristic of an electrolytic capacitor?

**C. High capacitance for a given volume**

G6A05 (C)

What is the approximate forward threshold voltage of a silicon junction diode?

**C. 0.7 volts**

G6A06 (B)

Why should wire-wound resistors not be used in RF circuits?

**B. The resistor's inductance could make circuit performance unpredictable**

G6A07 (A)

What are the operating points for a bipolar transistor used as a switch?

**A. Saturation and cutoff**

G6A08 (D)

Which of the following is characteristic of low voltage ceramic capacitors?

**D. Comparatively low cost**

G6A09 (B)

Which of the following describes MOSFET construction?

**B. The gate is separated from the channel by a thin insulating layer**



G6A10 (A)

Which element of a vacuum tube regulates the flow of electrons between cathode and plate?

A. Control grid

G6A11 (C)

What happens when an inductor is operated above its self-resonant frequency?

C. It becomes capacitive

G6A12 (A)

What is the primary purpose of a screen grid in a vacuum tube?

A. To reduce grid-to-plate capacitance

G6B01 (C)

What determines the performance of a ferrite core at different frequencies?

C. The composition, or "mix," of materials used

G6B02 (B)

What is meant by the term MMIC?

B. Monolithic Microwave Integrated Circuit

G6B03 (A)

Which of the following is an advantage of CMOS integrated circuits compared to TTL integrated circuits?

A. Low power consumption

G6B04 (C)

What is a typical upper frequency limit for low SWR operation of 50-ohm BNC connectors?

C. 4 GHz

G6B05 (D)

What is an advantage of using a ferrite core toroidal inductor?

A. Large values of inductance may be obtained

B. The magnetic properties of the core may be optimized for a specific range of frequencies

C. Most of the magnetic field is contained in the core

D. All these choices are correct

~~

G6B06 (D)

What kind of device is an integrated circuit operational amplifier?

D. Analog

G6B07 (A)

Which of the following describes a type N connector?

A. A moisture-resistant RF connector useful to 10 GHz

G6B08 (D)

How is an LED biased when emitting light?

D. Forward biased

G6B10 (A)

How does a ferrite bead or core reduce common-mode RF current on the shield of a coaxial cable?

A. By creating an impedance in the current's path

G6B11 (B)

What is an SMA connector?

B. A small threaded connector suitable for signals up to several GHz

G6B12 (C)

Which of these connector types is commonly used for low frequency or dc signal connections to a transceiver?

C. RCA Phono

G7A01 (B)

What is the function of a power supply bleeder resistor?

B. It discharges the filter capacitors when power is removed

G7A02 (C)

Which of the following components are used in a power supply filter network?

C. Capacitors and inductors

G7A03 (A)

Which type of rectifier circuit uses two diodes and a center-tapped transformer?

A. Full-wave

G7A04 (A)

What is characteristic of a half-wave rectifier in a power supply?

A. Only one diode is required

G7A05 (B)

What portion of the AC cycle is converted to DC by a half-wave rectifier?

B. 180 degrees

G7A06 (D)

What portion of the AC cycle is converted to DC by a full-wave rectifier?

D. 360 degrees

G7A07 (A)

What is the output waveform of an unfiltered full-wave rectifier connected to a resistive load?

A. A series of DC pulses at twice the frequency of the AC input

G7A08 (C)

Which of the following is characteristic of a switchmode power supply as compared to a linear power supply?

C. High-frequency operation allows the use of smaller components

G7A09 (C)

Which symbol in figure G7-1 represents a field effect transistor?

C. Symbol 1

G7A10 (D)

Which symbol in figure G7-1 represents a Zener diode?

D. Symbol 5

G7A11 (B)

Which symbol in figure G7-1 represents an NPN junction transistor?

B. Symbol 2

G7A12 (C)

Which symbol in Figure G7-1 represents a solid core transformer?

C. Symbol 6

G7A13 (A)

Which symbol in Figure G7-1 represents a tapped inductor?

A. Symbol 7

G7B01 (B)

What is the purpose of neutralizing an amplifier?

B. To eliminate self-oscillations

G7B02 (D)

Which of these classes of amplifiers has the highest efficiency?

D. Class C

G7B03 (B)

Which of the following describes the function of a two-input AND gate?

B. Output is high only when both inputs are high

G7B04 (A)

In a Class A amplifier, what percentage of the time does the amplifying device conduct?

A. 100%

G7B05 (C)

How many states does a 3-bit binary counter have?

C. 8

G7B06 (A)

What is a shift register?

A. A clocked array of circuits that passes data in steps along the array

G7B07 (D)

Which of the following are basic components of a sine wave oscillator?

D. A filter and an amplifier operating in a feedback loop

G7B08 (B)

How is the efficiency of an RF power amplifier determined?

B. Divide the RF output power by the DC input power

G7B09 (C)

What determines the frequency of an LC oscillator?

**C. The inductance and capacitance in the tank circuit**

G7B10 (B)

Which of the following describes a linear amplifier?

**B. An amplifier in which the output preserves the input waveform**

G7B11 (B)

For which of the following modes is a Class C power stage appropriate for amplifying a modulated signal?

**B. FM**

G7C01 (B)

What circuit is used to select one of the sidebands from a balanced modulator?

**B. Filter**

G7C02 (D)

What output is produced by a balanced modulator?

**D. Double-sideband modulated RF**

G7C03 (B)

What is one reason to use an impedance matching transformer at a transmitter output?

**B. To present the desired impedance to the transmitter and feed line**

G7C04 (D)

How is a product detector used?

**D. Used in a single sideband receiver to extract the modulated signal**

G7C05 (D)

Which of the following is characteristic of a direct digital synthesizer (DDS)?

**D. Variable output frequency with the stability of a crystal oscillator**

G7C06 (A)

Which of the following is an advantage of a digital signal processing (DSP) filter compared to an analog filter?

**A. A wide range of filter bandwidths and shapes can be created**

G7C07 (A)

What term specifies a filter's attenuation inside its passband?

**A. Insertion loss**

G7C08 (D)

Which parameter affects receiver sensitivity?

**D. All these choices are correct**

G7C09 (B)

What is the phase difference between the I and Q RF signals that software-defined radio (SDR) equipment uses for modulation and demodulation?

**B. 90 degrees**

G7C10 (B)

What is an advantage of using I-Q modulation with software-defined radios (SDRs)?

**B. All types of modulation can be created with appropriate processing**

G7C11 (D)

Which of these functions is performed by software in a software-defined radio (SDR)?

**D. All these choices are correct**

G7C12 (C)

What is the frequency above which a low-pass filter's output power is less than half the input power?

**C. Cutoff frequency**

G7C13 (D)

What term specifies a filter's maximum ability to reject signals outside its passband?

**D. Ultimate rejection**

G7C14 (A)

The bandwidth of a band-pass filter is measured between what two frequencies?

**A. Upper and lower half-power**

G8A01 (B)

How is direct binary FSK modulation generated?

**B. By changing an oscillator's frequency directly with a digital control signal**

G8A02 (B)

What is the name of the process that changes the phase angle of an RF signal to convey information?

**B. Phase modulation**

G8A03 (D)

What is the name of the process that changes the instantaneous frequency of an RF wave to convey information?

**D. Frequency modulation**

G8A04 (B)

What emission is produced by a reactance modulator connected to a transmitter RF amplifier stage?

**B. Phase modulation**

G8A05 (D)

What type of modulation varies the instantaneous power level of the RF signal?

**D. Amplitude modulation**

G8A06 (D)

Which of the following is characteristic of QPSK31?

**A. It is sideband sensitive**

**B. Its encoding provides error correction**

**C. Its bandwidth is approximately the same as BPSK31**

**D. All these choices are correct**

~~

G8A07 (A)

Which of the following phone emissions uses the narrowest bandwidth?

A. Single sideband

G8A08 (D)

Which of the following is an effect of overmodulation?

D. Excessive bandwidth

G8A09 (A)

What type of modulation is used by FT8?

A. 8-tone frequency shift keying

G8A10 (C)

What is meant by the term “flat-topping,” when referring to an amplitude-modulated phone signal?

C. Signal distortion caused by excessive drive or speech levels

G8A11 (A)

What is the modulation envelope of an AM signal?

A. The waveform created by connecting the peak values of the modulated signal

G8A12 (D)

What is QPSK modulation?

D. Modulation in which digital data is transmitted using 0-, 90-, 180- and 270-degrees phase shift to represent pairs of bits

G8A13 (C)

What is a link budget?

C. The sum of transmit power and antenna gains minus system losses as seen at the receiver

G8A14 (B)

What is link margin?

B. The difference between received power level and minimum required signal level at the input to the receiver

G8B01 (B)

Which mixer input is varied or tuned to convert signals of different frequencies to an intermediate frequency (IF)?

B. Local oscillator

G8B02 (B)

What is the term for interference from a signal at twice the IF frequency from the desired signal?

B. Image response

G8B03 (A)

What is another term for the mixing of two RF signals?

A. Heterodyning

~~

G8B04 (D)

What is the stage in a VHF FM transmitter that generates a harmonic of a lower frequency signal to reach the desired operating frequency?

D. Multiplier

G8B05 (C)

Which intermodulation products are closest to the original signal frequencies?

C. Odd-order

G8B06 (D)

What is the total bandwidth of an FM phone transmission having 5 kHz deviation and 3 kHz modulating frequency?

D. 16 kHz

G8B07 (B)

What is the frequency deviation for a 12.21 MHz reactance modulated oscillator in a 5 kHz deviation, 146.52 MHz FM phone transmitter?

B. 416.7 Hz

G8B08 (B)

Why is it important to know the duty cycle of the mode you are using when transmitting?

To allow time for the other station to break in during a transmission

B. Some modes have high duty cycles that could exceed the transmitter's average power rating

G8B09 (D)

Why is it good to match receiver bandwidth to the bandwidth of the operating mode?

D. It results in the best signal-to-noise ratio

G8B10 (B)

What is the relationship between transmitted symbol rate and bandwidth?

B. Higher symbol rates require wider bandwidth

G8B11 (C)

What combination of a mixer's Local Oscillator (LO) and RF input frequencies is found in the output?

C. The sum and difference

G8B12 (A)

What process combines two signals in a non-linear circuit to produce unwanted spurious outputs?

A. Intermodulation

G8B13 (C)

Which of the following is an odd-order intermodulation product of frequencies F1 and F2?

C.  $2F_1 - F_2$

G8C01 (C)

On what band do amateurs share channels with the unlicensed Wi-Fi service?

C. 2.4 GHz

G8C02 (A)

Which digital mode is used as a low-power beacon for assessing HF propagation?

A. WSPR

G8C03 (C)

What part of a packet radio frame contains the routing and handling information?

C. Header

G8C04 (C)

Which of the following describes Baudot code?

C. A 5-bit code with additional start and stop bits

G8C05 (A)

In an ARQ mode, what is meant by a NAK response to a transmitted packet?

A. Request retransmission of the packet

G8C06 (B)

What action results from a failure to exchange information due to excessive transmission attempts when using an ARQ mode?

B. The connection is dropped

G8C07 (B)

Which of the following narrow-band digital modes can receive signals with very low signal-to-noise ratios?

B. FT8

G8C08 (B)

Which of the following statements is true about PSK31?

B. Upper case letters use longer Varicode bit sequences and thus slow down transmission

G8C09 (B)

Which is true of mesh network microwave nodes?

B. If one node fails, a packet may still reach its target station via an alternate node

G8C10 (C)

How does forward error correction (FEC) allow the receiver to correct data errors?

C. By transmitting redundant information with the data

G8C11 (D)

How are the two separate frequencies of a Frequency Shift Keyed (FSK) signal identified?

D. Mark and space



G8C12 (A)

Which type of code is used for sending characters in a PSK31 signal?

A. Varicode

G8C13 (D)

What is indicated on a waterfall display by one or more vertical lines on either side of a data mode or RTTY signal?

D. Overmodulation

G8C14 (C)

Which of the following describes a waterfall display?

C. Frequency is horizontal, signal strength is intensity, time is vertical

G8C15 (C)

What does an FT8 signal report of +3 mean?

C. The signal-to-noise ratio is equivalent to +3dB in a 2.5 kHz bandwidth

G8C16 (D)

Which of the following provide digital voice modes?

D. DMR, D-STAR, and SystemFusion

G9A01 (A)

Which of the following factors determine the characteristic impedance of a parallel conductor feed line?

A. The distance between the centers of the conductors and the radius of the conductors

G9A02 (B)

What is the relationship between high standing wave ratio (SWR) and transmission line loss?

B. High SWR increases loss in a lossy transmission line

G9A03 (D)

What is the nominal characteristic impedance of "window line" transmission line?

D. 450 ohms

G9A04 (C)

What causes reflected power at an antenna's feed point?

C. A difference between feed line impedance and antenna feed point impedance

G9A05 (B)

How does the attenuation of coaxial cable change with increasing frequency?

B. Attenuation increases

G9A06 (D)

In what units is RF feed line loss usually expressed?

D. Decibels per 100 feet

G9A07 (D)

What must be done to prevent standing waves on a feed line connected to an antenna?

D. The antenna feed point impedance must be matched to the characteristic impedance of the feed line

G9A08 (B)

If the SWR on an antenna feed line is 5:1, and a matching network at the transmitter end of the feed line is adjusted to present a 1:1 SWR to the transmitter, what is the resulting SWR on the feed line?

B. 5:1

G9A09 (A)

What standing wave ratio results from connecting a 50-ohm feed line to a 200-ohm resistive load?

A. 4:1

G9A10 (D)

What standing wave ratio results from connecting a 50-ohm feed line to a 10-ohm resistive load?

D. 5:1

G9A11 (A)

What is the effect of transmission line loss on SWR measured at the input to the line?

A. Higher loss reduces SWR measured at the input to the line

G9B01 (B)

What is a characteristic of a random-wire HF antenna connected directly to the transmitter?

B. Station equipment may carry significant RF current

G9B02 (B)

Which of the following is a common way to adjust the feed point impedance of an elevated quarter-wave ground-plane vertical antenna to be approximately 50 ohms?

B. Slope the radials downward

G9B03 (D)

Which of the following best describes the radiation pattern of a quarter-wave ground-plane vertical antenna?

D. Omnidirectional in azimuth

G9B04 (A)

What is the radiation pattern of a dipole antenna in free space in a plane containing the conductor?

A. It is a figure-eight at right angles to the antenna

G9B05 (C)

How does antenna height affect the azimuthal radiation pattern of a horizontal dipole HF antenna at elevation angles higher than about 45 degrees?

C. If the antenna is less than 1/2 wavelength high, the azimuthal pattern is almost omnidirectional

G9B06 (C)

Where should the radial wires of a ground-mounted vertical antenna system be placed?

C. On the surface or buried a few inches below the ground

G9B07 (B)

How does the feed point impedance of a horizontal 1/2 wave dipole antenna change as the antenna height is reduced to 1/10 wavelength above ground?

**B. It steadily decreases**

G9B08 (A)

How does the feed point impedance of a 1/2 wave dipole change as the feed point is moved from the center toward the ends?

**A. It steadily increases**

G9B09 (A)

Which of the following is an advantage of using a horizontally polarized as compared to a vertically polarized HF antenna?

**A. Lower ground losses**

G9B10 (D)

What is the approximate length for a 1/2 wave dipole antenna cut for 14.250 MHz?

**D. 33 feet**

G9B11 (C)

What is the approximate length for a 1/2 wave dipole antenna cut for 3.550 MHz?

**C. 132 feet**

G9B12 (A)

What is the approximate length for a 1/4 wave monopole antenna cut for 28.5 MHz?

**A. 8 feet**

G9C01 (A)

Which of the following would increase the bandwidth of a Yagi antenna?

**A. Larger-diameter elements**

G9C02 (B)

What is the approximate length of the driven element of a Yagi antenna?

**B. 1/2 wavelength**

G9C03 (A)

How do the lengths of a three-element Yagi reflector and director compare to that of the driven element?

**A. The reflector is longer, and the director is shorter**

G9C04 (B)

How does antenna gain in dBi compare to gain stated in dBd for the same antenna?

**B. Gain in dBi is 2.15 dB higher**

G9C05 (A)

What is the primary effect of increasing boom length and adding directors to a Yagi antenna?

**A. Gain increases**

G9C07 (C)

What does “front-to-back ratio” mean in reference to a Yagi antenna?

C. The power radiated in the major lobe compared to that in the opposite direction

G9C08 (D)

What is meant by the “main lobe” of a directive antenna?

D. The direction of maximum radiated field strength from the antenna

G9C09 (B)

In free space, how does the gain of two three-element, horizontally polarized Yagi antennas spaced vertically 1/2 wavelength apart typically compare to the gain of a single three-element Yagi?

B. Approximately 3 dB higher

G9C10 (D)

Which of the following can be adjusted to optimize forward gain, front-to-back ratio, or SWR bandwidth of a Yagi antenna?

A. The physical length of the boom

B. The number of elements on the boom

C. The spacing of each element along the boom

D. All these choices are correct

G9C11 (A)

What is a beta or hairpin match?

A. A shorted transmission line stub placed at the feed point of a Yagi antenna to provide impedance matching

G9C12 (A)

Which of the following is a characteristic of using a gamma match with a Yagi antenna?

A. It does not require the driven element to be insulated from the boom

G9D01 (A)

Which of the following antenna types will be most effective as a near vertical incidence skywave (NVIS) antenna for short-skip communications on 40 meters during the day?

A. A horizontal dipole placed between 1/10 and 1/4 wavelength above the ground

G9D02 (D)

What is the feed point impedance of an end-fed half-wave antenna?

D. Very high

G9D03 (C)

In which direction is the maximum radiation from a VHF/UHF “halo” antenna?

C. Omnidirectional in the plane of the halo

G9D04 (A)

What is the primary function of antenna traps?

A. To enable multiband operation

~~

G9D05 (D)

What is an advantage of vertically stacking horizontally polarized Yagi antennas?

**D. It narrows the main lobe in elevation**

G9D06 (A)

Which of the following is an advantage of a log-periodic antenna?

**A. Wide bandwidth**

G9D07 (A)

Which of the following describes a log-periodic antenna?

**A. Element length and spacing vary logarithmically along the boom**

G9D08 (B)

How does a "screwdriver" mobile antenna adjust its feed point impedance?

**B. By varying the base loading inductance**

G9D09 (A)

What is the primary use of a Beverage antenna?

**A. Directional receiving for MF and low HF bands**

G9D10 (B)

In which direction or directions does an electrically small loop (less than 1/10 wavelength in circumference) have nulls in its radiation pattern?

**B. Broadside to the loop**

G9D11 (D)

Which of the following is a disadvantage of multiband antennas?

**D. They have poor harmonic rejection**

G9D12 (A)

What is the common name of a dipole with a single central support?

**A. Inverted V**

G0A01 (A)

What is one way that RF energy can affect human body tissue?

**A. It heats body tissue**

G0A02 (D)

Which of the following is used to determine RF exposure from a transmitted signal?

**A. Its duty cycle**

**B. Its frequency**

**C. Its power density**

**D. All these choices are correct**

~~

G0A03 (D) [97.13(c)(1)]

How can you determine that your station complies with FCC RF exposure regulations?

- A. By calculation based on FCC OET Bulletin 65
- B. By calculation based on computer modeling
- C. By measurement of field strength using calibrated equipment
- D. All these choices are correct

G0A04 (D)

What does "time averaging" mean when evaluating RF radiation exposure?

- D. The total RF exposure averaged over a certain period

G0A05 (A) [97.13(c)(2), 1.1307(b)]

What must you do if an evaluation of your station shows that the RF energy radiated by your station exceeds permissible limits for possible human absorption?

- A. Take action to prevent human exposure to the excessive RF fields

G0A06 (A) [97.13(c)(2), 1.1307(1)(b)(3)(i)]

What must you do if your station fails to meet the FCC RF exposure exemption criteria?

- A. Perform an RF Exposure Evaluation in accordance with FCC OET Bulletin 65

G0A07 (A)

What is the effect of modulation duty cycle on RF exposure?

- A. A lower duty cycle permits greater power levels to be transmitted

G0A08 (C) [97.13(c)(2)]

Which of the following steps must an amateur operator take to ensure compliance with RF safety regulations?

- C. Perform a routine RF exposure evaluation and prevent access to any identified high exposure areas

G0A09 (B)

What type of instrument can be used to accurately measure an RF field strength?

- B. A calibrated field strength meter with a calibrated antenna

G0A10 (C)

What should be done if evaluation shows that a neighbor might experience more than the allowable limit of RF exposure from the main lobe of a directional antenna?

- C. Take precautions to ensure that the antenna cannot be pointed in their direction when they are present

G0A11 (C)

What precaution should be taken if you install an indoor transmitting antenna?

- C. Make sure that MPE limits are not exceeded in occupied areas

G0A12 (D) [1.1307(1)(b)(3)(i)(A)]

What stations are subject to the FCC rules on RF exposure?

- D. All stations with a time-averaged transmission of more than one milliwatt

~~

G0B01 (A)

Which wire or wires in a four-conductor 240 VAC circuit should be attached to fuses or circuit breakers?

A. Only the hot wires

G0B02 (C)

According to the National Electrical Code, what is the minimum wire size that may be used safely for wiring with a 20-ampere circuit breaker?

C. AWG number 12

G0B03 (D)

Which size of fuse or circuit breaker would be appropriate to use with a circuit that uses AWG number 14 wiring?

D. 15 amperes

G0B04 (B)

Where should the station's lightning protection ground system be located?

B. Outside the building

G0B05 (B)

Which of the following conditions will cause a ground fault circuit interrupter (GFCI) to disconnect AC power?

B. Current flowing from one or more of the hot wires directly to ground

G0B06 (C)

Which of the following is covered by the National Electrical Code?

C. Electrical safety of the station

G0B07 (B)

Which of these choices should be observed when climbing a tower using a safety harness?

B. Confirm that the harness is rated for the weight of the climber and that it is within its allowable service life

G0B08 (B)

What should be done before climbing a tower that supports electrically powered devices?

B. Make sure all circuits that supply power to the tower are locked out and tagged

G0B09 (A)

Which of the following is true of an emergency generator installation?

A. The generator should be operated in a well-ventilated area

G0B10 (A)

Which of the following is a danger from lead-tin solder?

A. Lead can contaminate food if hands are not washed carefully after handling the solder

G0B11 (D)

Which of the following is required for lightning protection ground rods?

D. They must be bonded together with all other grounds

~~

G0B12 (C)

What is the purpose of a power supply interlock?

C. To ensure that dangerous voltages are removed if the cabinet is opened

G0B13 (A)

Where should lightning arrestors be located?

A. Where the feed lines enter the building

~~~end of question pool text~~~

NOTE: One graphic is required for certain questions in section G7 and is included on the following page.



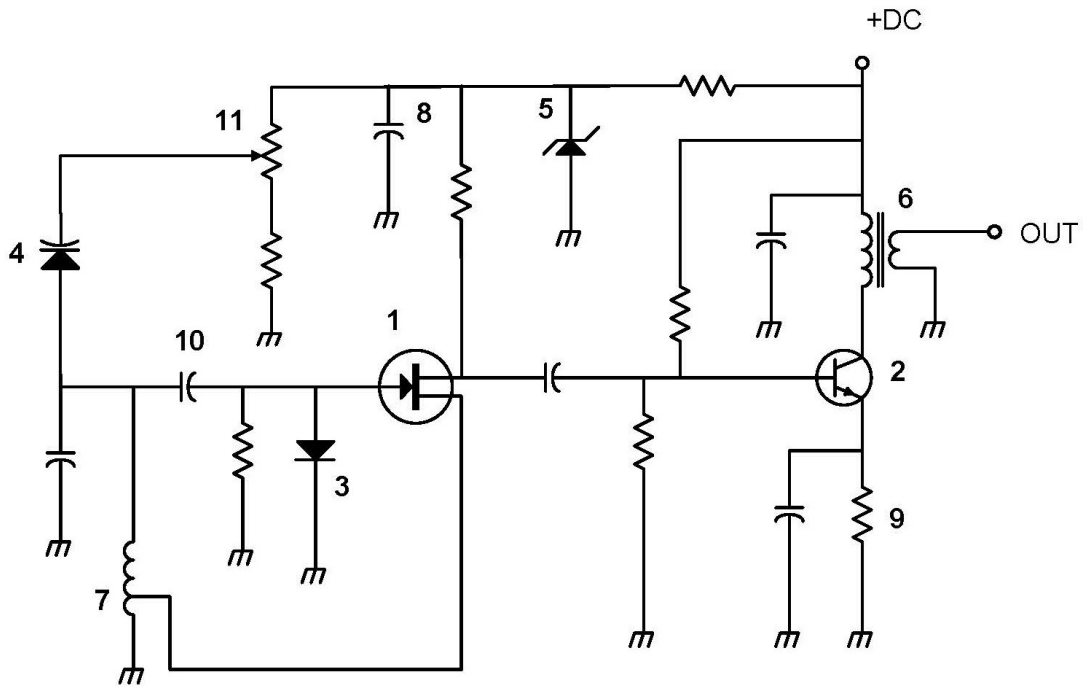

Figure G7-1